

**PRODUCT SPECIFICATIONS**

ezH2O® Surface Mount Mechanical Bottle Filling Station Filtered Non-Refrigerated Stainless. Features shall include Ambient Water, Filtered, Laminar Flow, Mechanically Activated, New Offering, Vandal Resistant. Product shall be Wall Mount (On Wall), for Indoor applications, serving 1 station(s).



<b>Special Features:</b>	Ambient Water, Filtered, Laminar Flow, Mechanically Activated, New Offering, Vandal Resistant
<b>Finish:</b>	Stainless Steel
<b>Power:</b>	No Electrical Required
<b>Mounting Type:</b>	Wall Mount (On Wall)
<b>Chilling Capacity:</b>	Non-refrigerated
<b>Dimensions (L x W x H):</b>	27" x 18" x 5-1/4"
<b>Approx. Shipping Weight:</b>	34 lbs.
<b>Installation Location:</b>	Indoor
<b>No. of Stations Served:</b>	1

- Laminar flow provides clean fill with minimal splash.

**Included with Product:**      **Bottle filler, Filter box**

**Ships in one box.**

A Century of Tradition and Quality. For more than 100 years, Elkay has been making innovative products and providing exceptional customer care. We take pride in offering plumbing products that make life easier, inspire change and leave the world a better place.

[Installation Instructions \(PDF\) - 2000001526](#)

Water Systems are warranted for 12 months from date of installation. **Warranty pertains to drinking water applications only. Non-drinking water applications are not covered under warranty.**

[Warranty \(PDF\)](#)

PART: \_\_\_\_\_ QTY: \_\_\_\_\_

PROJECT: \_\_\_\_\_

CONTACT: \_\_\_\_\_

DATE: \_\_\_\_\_

NOTES: \_\_\_\_\_

APPROVAL: \_\_\_\_\_

*In keeping with our policy of continuing product improvement, Elkay reserves the right to change product specifications without notice. Please visit [elkay.com](http://elkay.com) for the most current version of Elkay product specification sheets. This specification describes an Elkay product with design, quality, and functional benefits to the user. When making a comparison of other producers' offerings, be certain these features are not overlooked.*

Optional Accessories		
<a href="#">51300C</a>	WaterSentry <sup>®</sup> Lead + Microplastics NSF/ANSI Certified Filter (Bottle Fillers) <a href="#">Spec Sheet (PDF)</a>	

**IMPORTANT!**  
**INSTALLATION NOTES:**  
Ensure wall is structurally sound to bear the loads imparted by the Surface Mount Bottle Filler.

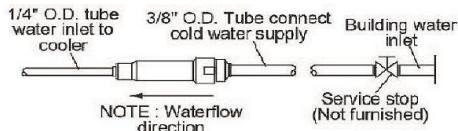

**OPERATION OF QUICK CONNECT FITTINGS**

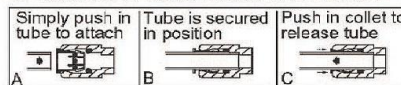

Pushing tube in before pulling it out helps to release tube

**ADA STAND ALONE MOUNTING**

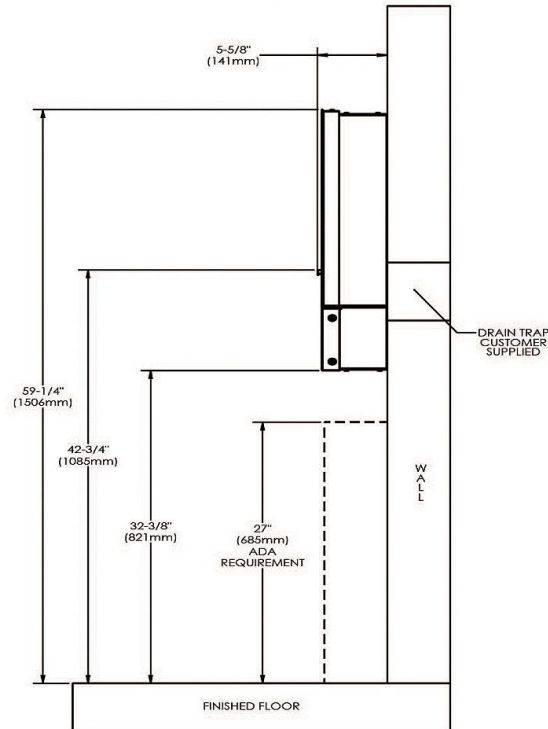
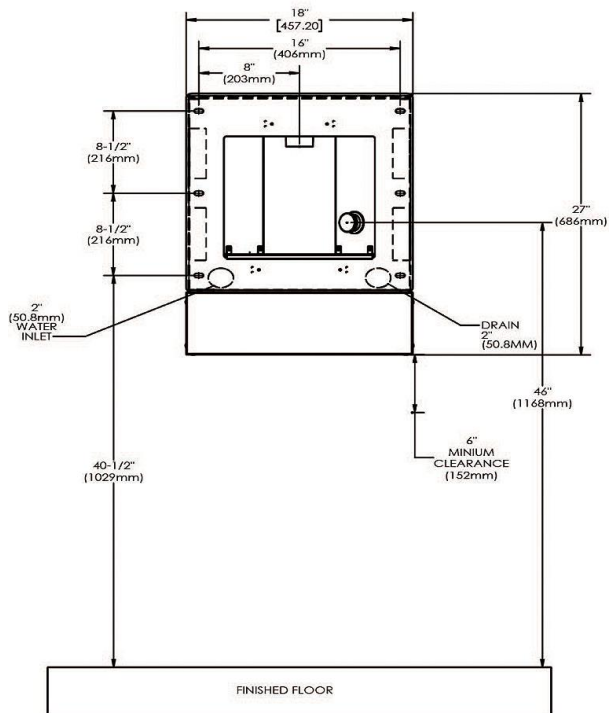

**LEGEND:**

A = Recommended water supply location; 1/2" IPS maximum pipe size. Service stop valve not furnished.  
B = Recommended waste location. Waste shown in wall but may be behind wall outlet 1-1/4" O.D. (Trap not furnished).  
C = 7/16" X 3/4" Obround mounting holes for fastening backplate to wall.  
NOTE: New Installations Must Use Ground Fault Circuit Interrupter (GFCI). It is highly recommended that the circuit be dedicated and the load protection be sized for 20 amps.

In keeping with our policy of continuing product improvement, Elkay reserves the right to change product specifications without notice. Please visit [elkay.com](http://elkay.com) for the most current version of Elkay product specification sheets. This specification describes an Elkay product with design, quality, and functional benefits to the user. When making a comparison of other producers' offerings, be certain these features are not overlooked.

### PRODUCT SPECIFICATIONS

Single Level Filter Maintenance Kit with Filter. Overall dimensions are 17-9/16" x 13-3/4" x 10-9/16".

<b>Special Features:</b>	Filtered
<b>Mounting Type:</b>	Wall Mount (On Wall)
<b>Finish:</b>	Stainless Steel
<b>Dimensions:</b>	17-9/16" x 13-3/4" x 10-9/16"
<b>Shipping Weight:</b>	8 lbs.
<b>Flow Rate:</b>	1.5 GPM (5.6 L/m)
<b>Capacity:</b>	
<b>Temperature:</b>	40-100°F (4-38°C)
<b>Initial Pressure Drop:</b>	2-5 PSI (14-34 kPa)
<b>Maximum Pressure:</b>	105 PSI (724 kPa)
<b>Minimum Pressure:</b>	20 PSI (138 kPa)
<b>Water Inlet:</b>	3/8" (9.5mm) O.D. tube
<b>Water Outlet:</b>	1/4" (6.4mm) O.D. tube

**Special Note:** Compatible with single-level EZ / LZ filtered models only and 36 in. of space on left side of drinking water unit provides sufficient access to conduct filter replacement.

- Cooler side panel provides convenient access to filter, water shut-off valve, and power supply without removing entire wrapper
- Two alignment pins on the panel make it easy to attach
- At least 36 in. of space on left side of drinking water unit is recommended
- Retrofit kit is compatible with Elkay® EZ/LZ single-level filtered coolers and bottle filling stations
- WaterSentry® 51300C 3,000-gallon filter is tested and certified to NSF 42 and 53 for the reduction of lead, Class 1 particulate, chlorine taste and odor
- Kit includes cooler wrapper with side access panel, 51300C water filter, security Torx bit and screws



**Included with Product:** One stainless steel wrapper with side access panel (for single level stations) and filter

A Century of Tradition and Quality.

For more than 100 years, Elkay has been making innovative products and providing exceptional customer care. We take pride in offering plumbing products that make life easier, inspire change and leave the world a better place.

[Installation Instructions \(PDF\) - 200000888](#)

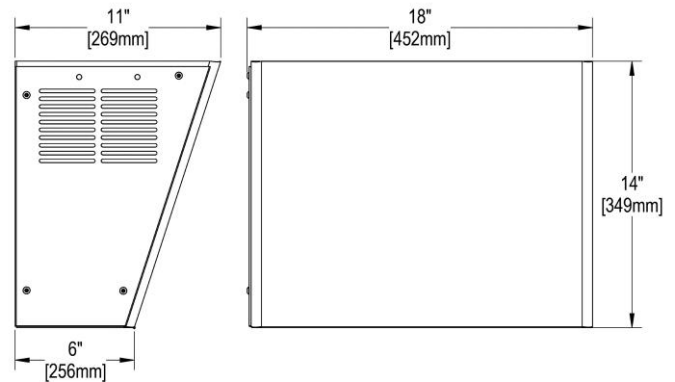

PART: \_\_\_\_\_ QTY: \_\_\_\_\_

PROJECT: \_\_\_\_\_

CONTACT: \_\_\_\_\_

DATE: \_\_\_\_\_

NOTES: \_\_\_\_\_

APPROVAL: \_\_\_\_\_

*In keeping with our policy of continuing product improvement, Elkay reserves the right to change product specifications without notice. Please visit [elkay.com](http://elkay.com) for the most current version of Elkay product specification sheets. This specification describes an Elkay product with design, quality, and functional benefits to the user. When making a comparison of other producers' offerings, be certain these features are not overlooked.*

**PRODUCT SPECIFICATIONS**

Universal Vandal-Resistant 3000 Gal. Filtration Kit with Filter Status Monitor. Overall dimensions are 7-7/8" x 5-7/8" x 16-3/8". Made of Stainless Steel.

<b>Special Features:</b>	Vandal Resistant, Filtered, Visual Filter Monitor
<b>Material:</b>	Stainless Steel
<b>Finish:</b>	Stainless Steel
<b>Dimensions:</b>	7-7/8" x 5-7/8" x 16-3/8"
<b>Shipping Weight:</b>	8 lbs.
<b>Flow Rate:</b>	1.5 GPM (5.6 L/m)
<b>Capacity:</b>	
<b>Temperature:</b>	40-100°F (4-38°C)
<b>Initial Pressure Drop:</b>	2-5 PSI (14-34 kPa)
<b>Maximum Pressure:</b>	105 PSI (724 kPa)
<b>Minimum Pressure:</b>	20 PSI (138 kPa)
<b>Water Inlet:</b>	3/8" (9.5mm) O.D. tube
<b>Water Outlet:</b>	1/4" (6.4mm) O.D. tube

**Special Note:** Includes WaterSentry Filter. Order 51300C as a replacement filter.

- Includes WaterSentry 3,000-gallon capacity filter
- 51300C filter is tested and certified to NSF 42 and 53 for the reduction of lead, Class 1 particulate and chlorine taste and odor
- Filter should be replaced every 3,000 gallons or 1 year after installation; replace sooner if unit is located in a high-traffic area in places such as schools and airports
- Vandal-resistant enclosure made from 20-gauge stainless steel to protect filter and discourage tampering; Torx bit included for added security
- Versatile mounting near accessible water line; box includes conduit punchouts on sides and bottom and an open back for thru-wall plumbing; vandal-resistant conduit not provided
- Universal box works with Elkay and non-Elkay units to turn any non-filtered cooler or fountain into a filtered unit
- LED filter status monitor and audio alert indicate when filter replacement is needed



**Included with Product:** WaterSentry Filter, Filter Status Monitor, 20-Gauge stainless steel mounting box

A Century of Tradition and Quality. For more than 100 years, Elkay has been making innovative products and providing exceptional customer care. We take pride in offering plumbing products that make life easier, inspire change and leave the world a better place.



**Product Compliance:** NSF 61  
NSF 372 (lead free)  
NSF 42  
NSF 53  
NSF 401



[Installation Instructions \(PDF\) - 2000001249](#)  
[Warranty \(PDF\)](#)

PART: \_\_\_\_\_ QTY: \_\_\_\_\_  
PROJECT: \_\_\_\_\_  
CONTACT: \_\_\_\_\_  
DATE: \_\_\_\_\_  
NOTES: \_\_\_\_\_  
APPROVAL: \_\_\_\_\_

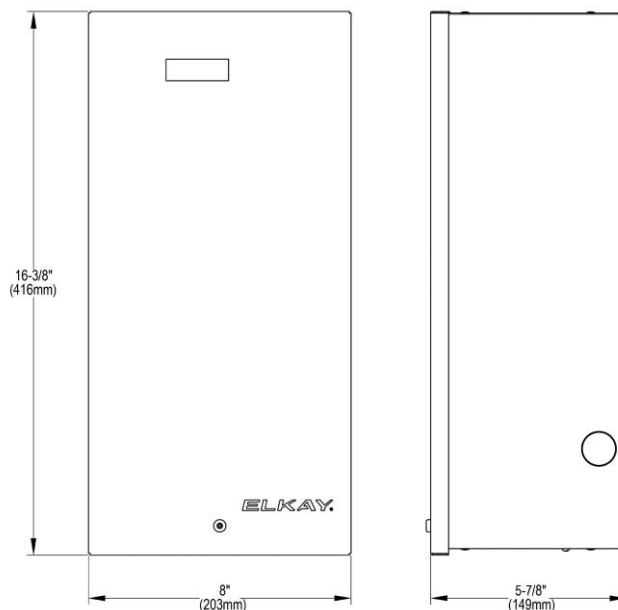

*In keeping with our policy of continuing product improvement, Elkay reserves the right to change product specifications without notice. Please visit [elkay.com](http://elkay.com) for the most current version of Elkay product specification sheets. This specification describes an Elkay product with design, quality, and functional benefits to the user. When making a comparison of other producers' offerings, be certain these features are not overlooked.*