

ELKAY[®]

SPECIFICATIONS

EZH20™ System Filtered Surface Mount Model LZWSSM

PRODUCT FEATURES

- Installs directly onto wall with robust hanging bracket for applications with limited wall depth
- Complete with drain; no bubbler required
- Sanitary, no-touch, sensor activation with automatic 20-second shut-off timer
- WaterSentry[®] Plus 3000 gallon filter included
- Silver Ion anti-microbial protection
- Quick fill rate is 1.5 gpm standard; 1.1 gpm when paired with remote chiller
- Laminar flow provides minimal splash
- Visual user interface display includes:
 - Filter Monitor indicating when replacement is necessary
 - Green Ticker™ counting the quantity of plastic bottles saved from waste
- Optional remote chiller packages installed within 15 feet delivers chilled drinking water

Bottle filling unit shall mount on wall surface and include hanging bracket. Unit shall include drain. Shall include an electronic sensor for no-touch activation with an automatic 20-second shut-off timer. Shall provide 1.1-1.5 gpm flow rate with laminar flow to minimize splashing. Shall include antimicrobial protected plastic components to prevent mold and mildew. Unit shall include the WaterSentry[®] Plus filter certified to NSF/ANSI 42 and 53 for taste and odor, chlorine, particulate and lead reduction with visual filter monitor to indicate when replacement is necessary. Unit shall meet ADA guidelines for parallel approach. Shall be a lead-free design which meets the Safe Drinking Act and is certified to NSF/ANSI 61 and California AB1953. Unit shall be certified to UL399 and CAN/CSA 22.2 No. 120. Unit shall be GreenSpec Listed.

SUGGESTED SPECIFICATION

IMAGES

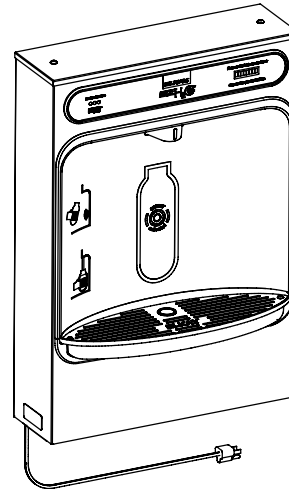

- 51300C Replacement filter (available as single or packs of 3, 12, 24 or 48)

OPTIONAL ACCESSORIES

Ideal for use in:

- Educational facilities
- Healthcare facilities
- Sport and fitness centers
- Airports
- Office buildings
- Other commercial buildings

APPLICATIONS

2222 Camden Court
Oak Brook, IL 60523

Phone: 630-572-3192
Web: Elkayusa.com



Third Party Certified to:

- UL399 and CAN/CSA 22.2 No. 120
- Lead-free compliance including NSF/ANSI 61 and CA AB1953
- NSF/ANSI 42 and 53 (Filter)

ROUGH - IN DIMENSIONS

*Rated for Indoor Use Only

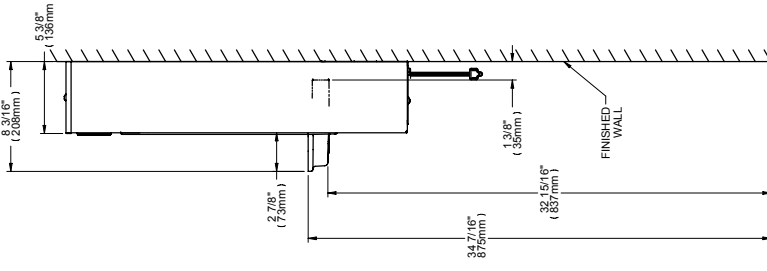
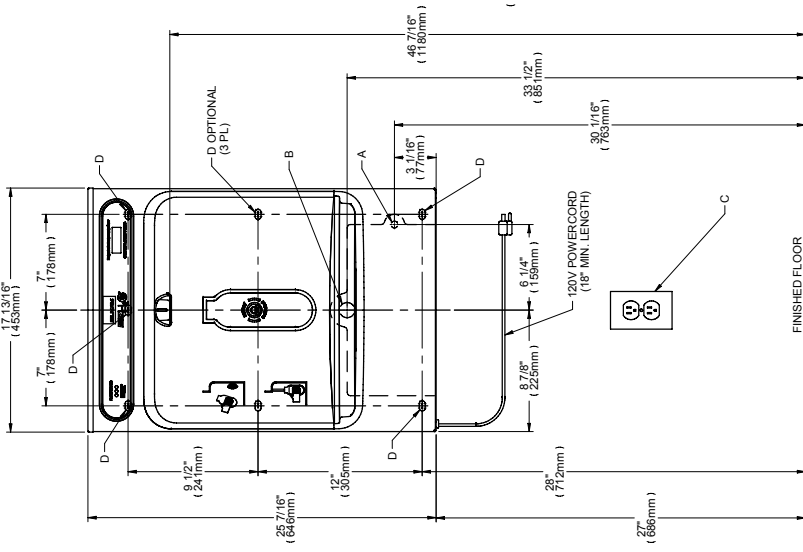

LEGEND:

- A = Recommended water supply location; 1/2" IPS maximum pipe size. Service stop valve not furnished.
- B = Recommended location for wasate outlet 1-1/4" O.D. maximum pipe size.
- C = Electrical outlet, three (3) conductor grounded. Locate within safe reach of power cord.
- D = 7/16" x 3/4" obround mounting holes for fastening backplate to wall.

Job Name: _____ Qty: _____

Date: _____

Contact Info (Name, Phone, Email): _____

Approval for Manufacture Signature and Date: _____

Specifications and measurements are subject to change without notification. Please visit elkayusa.com for most current version.

2222 Camden Court
Oak Brook, IL 60523
Phone: 630-672-3192
Web: Elkayusa.com

Model LZWSSM

ELKAY[®]

SPECIFICATIONS

EZH20™ System Filterless Surface Mount Model EZWSSM

PRODUCT FEATURES

- Installs directly onto wall with robust hanging bracket for applications with limited wall depth
- Complete with drain; no bubbler required
- Sanitary, no-touch, sensor activation with automatic 20-second shut-off timer
- Silver Ion anti-microbial protection
- Quick fill rate is 1.5 gpm standard; 1.1 gpm when paired with remote chiller
- Laminar flow provides minimal splash
- Visual user interface display includes:
 - Green Ticker™ counting the quantity of plastic bottles saved from waste
- Optional remote chiller packages installed within 15 feet delivers chilled drinking water

Bottle filling unit shall mount on wall surface and include hanging bracket. Unit shall include drain. Shall include an electronic sensor for no-touch activation with an automatic 20-second shut-off timer. Shall provide 1.1-1.5 gpm flow rate with laminar flow to minimize splashing. Shall include antimicrobial protected plastic components to prevent mold and mildew. Unit shall meet ADA guidelines for parallel approach. Shall be lead-free design which meets the Safe Drinking Act and is certified to NSF/ANSI 61 and California AB1953. Unit shall be certified to UL399 and CAN/CSA 22.2 No. 120. Unit shall be GreenSpec Listed.

SUGGESTED SPECIFICATION

IMAGES

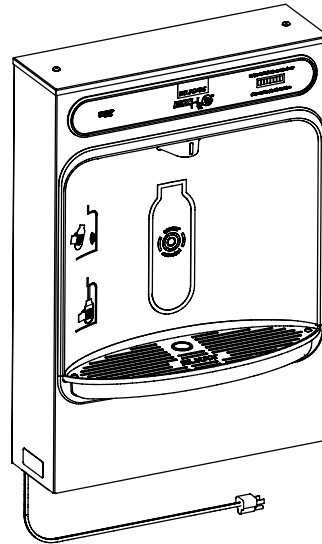

OPTIONAL ACCESSORIES

Ideal for use in:

- Educational facilities
- Healthcare facilities
- Sport and fitness centers
- Airports
- Office buildings
- Other commercial buildings

APPLICATIONS

2222 Camden Court Phone: 630-572-3192
Oak Brook, IL 60523 Web: Elkayusa.com



Third Party Certified to:

- UL399 and CAN/CSA 22.2 No. 120
- Lead-free compliance including NSF/ANSI 61 and CA AB1953

ROUGH - IN DIMENSIONS

*Rated for Indoor Use Only

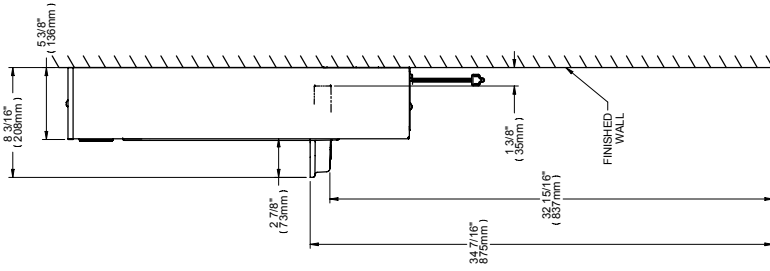
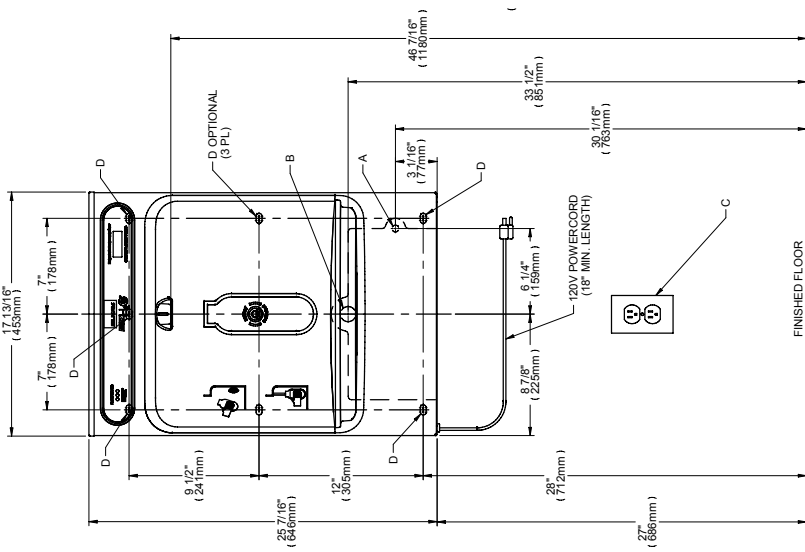

LEGEND:

- A = Recommended water supply location; 1/2" IPS maximum pipe size. Service stop valve not furnished.
- B = Recommended location for wasate outlet 1-1/4" O.D. maximum pipe size.
- C = Electrical outlet, three (3) conductor grounded. Locate within safe reach of power cord.
- D = 7/16" x 3/4" obround mounting holes for fastening backplate to wall.

Job Name: _____ Qty: _____

Date: _____

Contact Info (Name, Phone, Email): _____

Approval for Manufacture Signature and Date: _____

Specifications and measurements are subject to change without notification. Please visit elkayusa.com for most current version.

2222 Camden Court
Oak Brook, IL 60523
Phone: 630-672-3192
Web: Elkayusa.com

Model EZWSSM